

Application

AC-83 and AC-84 control dampers employ a rugged channel frame and triple-V blades for automatic air control and manual balancing in medium to high pressure and velocity applications.

Standard Construction

Frame: 8" x 2" x 12 ga. (203 x 51 x 2.8) galvanized steel channel.

Blades: 7³/₄" x 14 gauge (197 x 2.0) galvanized steel — triple-V. Parallel (model CD-83) or opposed (model CD-84) action.

Axles: 3/4" (19) diameter plated steel.

Linkage: Concealed in frame.

Bearings: Stainless steel sleeve-type, pivot in bushing, press fit into frame.

Control Shaft: 3/4" x 6" (19 x 152) round drive axle with shaft support bracket and bearing mounted to damper frame with factory mounted/welded manual locking quadrant.

Minimum Size: CD-83 (one blade): 6" x 7" (152 x 178)
 CD-83 or CD-84 (two blades): 6" x 12" (152 x 305)

Maximum Size: 48" x 72" (1219 x 1829) with seals
 48" x 96" (1219 x 2438) without seals

Options

- Factory installed external mount actuator:
 - 24 VAC 120 VAC 230 VAC
 - Pneumatic Modulating
- Stainless steel jamb seals.
- Low leakage blade edge seals (includes flexible metal jamb seals): PVC Silicone
- Stainless steel construction:
 - 304 316
- Vertical mounted blades with thrust washers.
- Bolt holes in damper frame:
 - One side Both sides

Ratings

Damper Width	Maximum System Pressure with seals	Maximum System Pressure without seals
22" (559)	10.0 in. wg (2.5 kPa)	15.0 in. wg (3.8 kPa)
36" (914)	10.0 in. wg (2.5 kPa)	10.0 in. wg (2.5 kPa)
48" (1219)	6.0 in. wg (1.5 kPa)	6.0 in. wg (1.5 kPa)

Max. Damper Width	Maximum Damper Height	Maximum System Velocity
28" (711)	96" (2438)	5000 fpm (25.4 m/s)
48" (1219)	56" (1422)	5000 fpm (25.4 m/s)
48" (1219)	96" (2438)	4000 fpm (20.3 m/s)

Leakage: 16.0 cfm/ft² @ 15.0 in. wg. (0.08 m³/s/ m² @ 3.8 kPa) with low leakage seals.

13.0 cfm/ft² @ 10.0 in. wg. (0.07 m³/s/ m² @ 2.5 kPa) with low leakage seals.

10.0 cfm/ft² @ 6 in. wg. (0.05 m³/s/ m² @ 1.5 kPa) with low leakage seals.

Temperature: -65°F to 250°F (-54°C to +121°C) with no seals or with silicone seals.

-10°F to 150°F (-23°C to +66°C) with PVC seals.

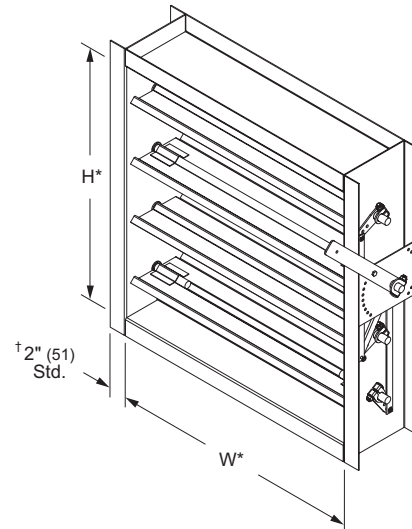

Model AC-84

*Damper dimensions furnished approximately net I.D..

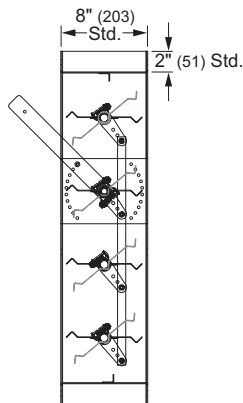

CD-83

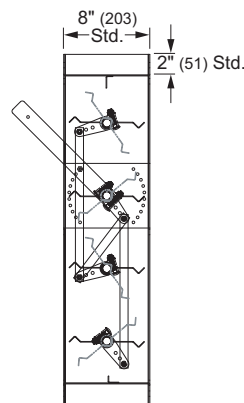

CD-84

† 2¹¹/₁₆" when equipped with frame mounted bearings.

CD-83 and CD-84 Bolt Hole Dimensions

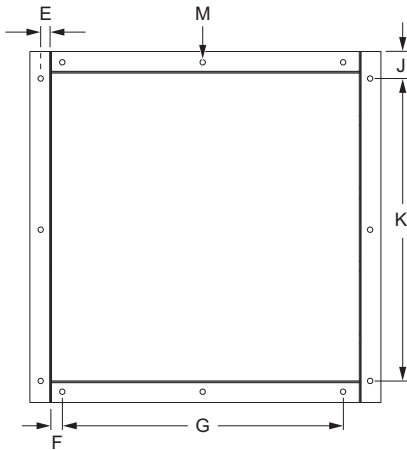

Dimension	Description
M _____ inches	Hole Diameter
E _____ inches	Centerline of Bolt Hole From Inside Edge of Frame
F _____ inches	First/Last Hole in Head/Sill
G ___ @ ___(x) inches	Number of Holes/Spacing in Head/Sill
J _____ inches	First/Last Hole in Jamb
K ___ @ ___(z) inches	Number of Holes/Spacing in Jamb

Airflow Performance Data

Pressure Loss vs. Velocity

Figure 5.3 — Ducted Inlet and Outlet

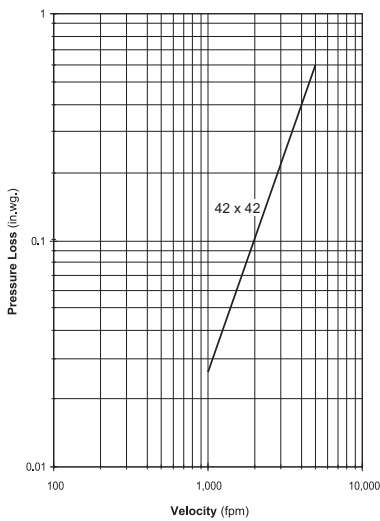

Pressure drop testing was performed in accordance with AMCA Standard 500-D using Figure 5.3 — Ducted Inlet and Outlet. All data has been corrected to represent air density of 0.075 lb/ft. Actual pressure drop in any ducted HVAC system is a combination of many elements. This information, along with analysis of other system influences, should be used to estimate actual pressure losses for a damper installed in a given HVAC system.



Ducted Inlet and Outlet

AMCA Figure 5.3 illustrates a fully ducted damper. This configuration represents the lowest pressure drop of the three test configurations because entrance and exit losses are minimized by straight duct runs upstream and downstream of the damper.

Pressure Limitations

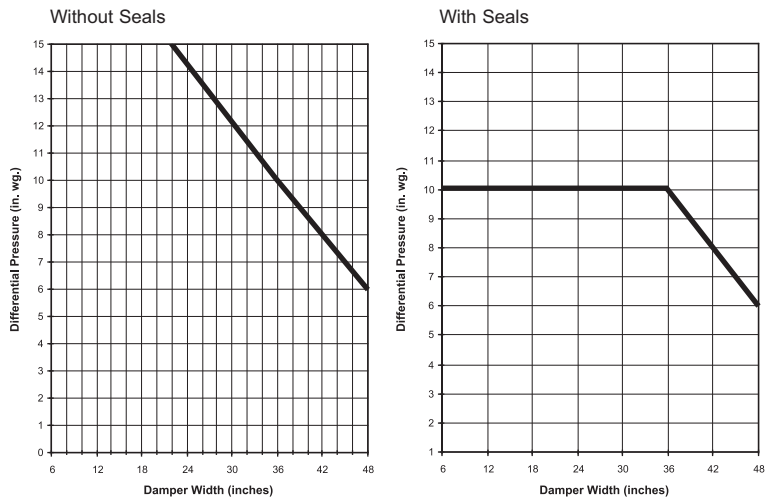

Velocity Limitations

