

Application

AC-93 and AC-94 industrial control dampers employ heavy duty airfoil blades, a rugged flanged frame, and options for ultra-low leakage in high temperature air and high pressure applications that makes it ideal for high performance air intake and discharge applications where ultra-low leakage is critical.

Standard Construction

Frame: 8" x 2" x 12 ga. (203 x 51 x 2.8) galvanized steel channel.

Blades: 16 gauge (1.5) galvanized steel airfoil. Parallel (model AC-93) or opposed (model AC-94) action.

Axles: 3/4" (19) diameter plated steel.

Linkage: 3/16" x 3/4" (5 x 19) plated steel tie bars and 3/8" (10) stainless steel pins concealed in frame.

Bearings: Stainless steel pressed into frame.

Control Shaft: 3/4" x 10" (19 x 254) round drive shaft with shaft support bracket and bearing mounted to damper frame with factory mounted/welded manual locking quadrant.

Lifting Lugs: 7/8" (22) diameter, one on each jamb of frame.

Minimum Size: AC-93 (one blade): 8" x 10" (203 x 254)
AC-94 (two blades): 8" x 12" (203 x 305)

Maximum Size: Single section: 60" x 96" (1524 x 2438)
Multiple sections: Unlimited

Options

- Factory mounted electric or pneumatic actuator.
- Stainless steel construction: 304 316
- Low leakage seals: Silicone blade edge seals are mechanically secured to blade and stainless steel jamb seals.
- Ultra low leakage seals: Silicone blade edge seals are mechanically secured to blade and stainless steel jamb seals. Requires optional 14 gauge (2) blades.
- 14 gauge (2) blades.
- High temperature construction.
- Vertical mounted blades with thrust washers.
- Bolt holes in damper frame:
 - One side
 - Both sides
- Outboard bearings.
- Extended perimeter mounting flange.

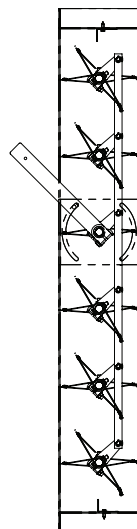

AC-93

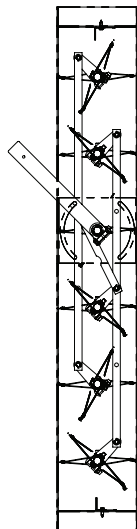

AC-94

Ratings

Damper Width	Maximum System Pressure	Maximum System Velocity
12" (305)	32.0 in. wg (8.0 kPa)	5000 fpm (25.4 m/s)
24" (610)	27.0 in. wg (6.7 kPa)	5000 fpm (25.4 m/s)
36" (914)	22.0 in. wg (5.5 kPa)	5000 fpm (25.4 m/s)
48" (1219)	17.0 in. wg (4.2 kPa)	5000 fpm (25.4 m/s)
60" (1524)	12.0 in. wg (3.0 kPa)	4000 fpm (20.3 m/s)

Maximum System Pressure	** Leakage with Seals (cfm/ft ²)	** Leakage with Ultra-Low Leakage Seals (cfm/ft ²)
15.0 in. wg (3.8 kPa)	11.5 (0.06 m ³ /s/m ²)	7.5 (0.04 m ³ /s/m ²)
10.0 in. wg (2.5 kPa)	8.5 (0.04 m ³ /s/m ²)	4.6 (0.02 m ³ /s/m ²)
6.0 in. wg (1.5 kPa)	5.8 (0.03 m ³ /s/m ²)	2.8 (0.02 m ³ /s/m ²)
2.0 in. wg (0.5 kPa)	4.0 (0.02 m ³ /s/m ²)	1.5 (0.01 m ³ /s/m ²)

Temperature: -25°F to 250°F (-32°C to +121°C), available up to 450°F (232°C) when required – consult with C&S

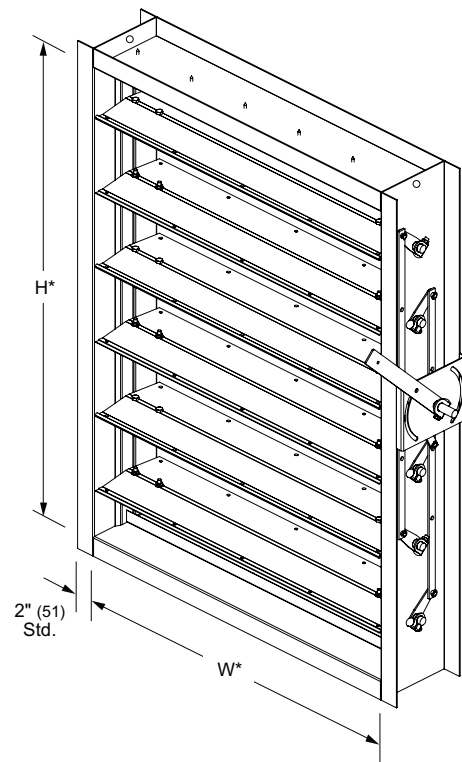

Model AC-94

* Damper dimensions furnished approximately net I.D.

** Results based upon a 36" x 48" (914 x 1219) damper. Maximum single section width for Ultra-Low leakage seals is 48" (1219).

NOTE: Dimensions in parentheses () are millimeters.

AC-93 and AC-94 Bolt Hole Dimensions

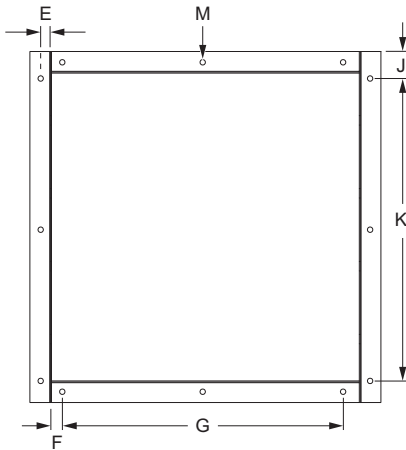

Dimension	Description
M _____ inches	Hole Diameter
E _____ inches	Centerline of Bolt Hole From Inside Edge of Frame
F _____ inches	First/Last Hole in Head/Sill
G ___ @ ___(x) inches	Number of Holes/Spacing in Head/Sill
J _____ inches	First/Last Hole in Jamb
K ___ @ ___(z) inches	Number of Holes/Spacing in Jamb

Airflow Performance Data

Pressure Loss vs. Velocity

Figure 5.3 — Ducted Inlet and Outlet

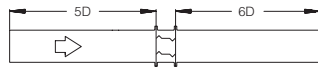
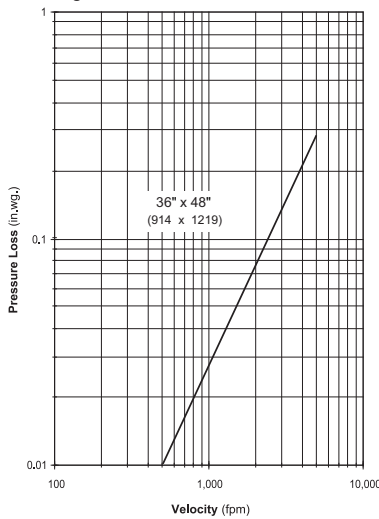

Ducted Inlet and Outlet

AMCA Figure 5.3 illustrates a fully ducted damper. This configuration represents the lowest pressure drop of the three test configurations because entrance and exit losses are minimized by straight duct runs upstream and downstream of the damper.

Pressure drop testing was performed in accordance with AMCA Standard 500-D using Figure 5.3 — Ducted Inlet and Outlet. All data has been corrected to represent air density of 0.075 lb/ft. Actual pressure drop in any ducted HVAC system is a combination of many elements. This information, along with analysis of other system influences, should be used to estimate actual pressure losses for a damper installed in a given HVAC system.

Pressure Limitations

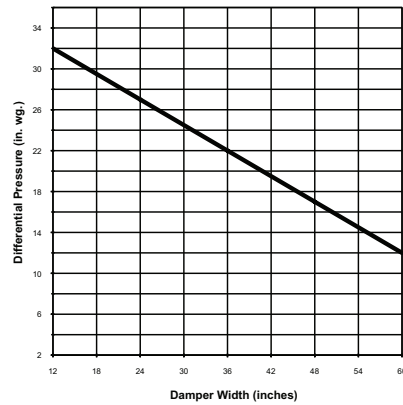

Velocity Limitations

