

Application

BD-84 backdraft dampers employ counterbalanced gravity operated triple-V blades and a rugged channel frame to restrict reverse airflow and to permit the forward flow of air in the intended direction. Adjustable counterbalances attached to the blades axles permit field adjustment to regulate start-to-open and full open blade operation. The BD-84 damper is intended to be mounted vertically in either exhaust or intake installations for medium to high velocity and pressure applications.

Standard Construction

Frame: 8" x 2" x 14 gauge (203 x 51 x 2.0) galvanized steel channel.

Blades: 6" x 16 gauge (152 x 1.5) galvanized steel — triple-V.

Axles: 1/2" (13) diameter plated steel.

Linkage: Concealed in frame.

Bearings: Steel ball bearing, press fit into frame.

Counterbalances: On-blade axle, crankarm and weights — adjustable.

Minimum Size: 6" x 6" (152 x 152)

Maximum Size: 48" x 96" (1219 x 2438)

Options

- Neoprene blade edge and stainless steel jamb seals.
- Type-304 stainless steel construction.
- Bolt holes in damper frame:
 - One side
 - Both sides

Ratings

Damper Width	Maximum System Pressure	Maximum System Velocity
12" (305)	10.0 in. wg (2.5 kPa)	3500 fpm (17.8 m/s)
24" (610)	8.0 in. wg (2.0 kPa)	3500 fpm (17.8 m/s)
36" (914)	6.0 in. wg (1.5 kPa)	3000 fpm (15.2 m/s)
48" (1219)	4.0 in. wg (1.0 kPa)	3000 fpm (15.2 m/s)

Leakage: 70 cfm/ft² @ 4 in. wg. (0.36 m/s @ 1.00k Pa) with no seals
40 cfm/ft² @ 1 in. wg. (0.21 m/s @ 0.25k Pa) with no seals

Temperature: -25°F to 250°F (-32°C to 121°C) with no seals.
-10°F to 150°F (-23°C to 66°C) with seals.

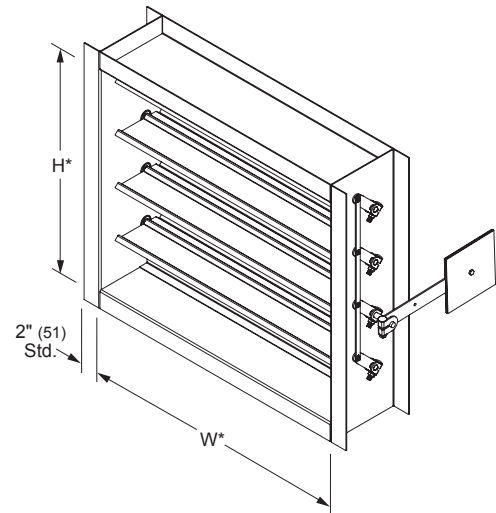

Model BD-84
(standard)

*Damper dimensions furnished approximately net I.D..

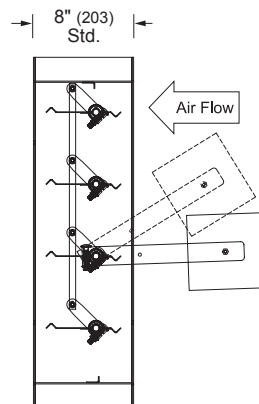

NOTE: Counterbalanced to assist opening.

Information is subject to change without notice or obligation.

NOTE: Dimensions in parentheses () are millimeters.

BD-84 Bolt Hole Dimensions

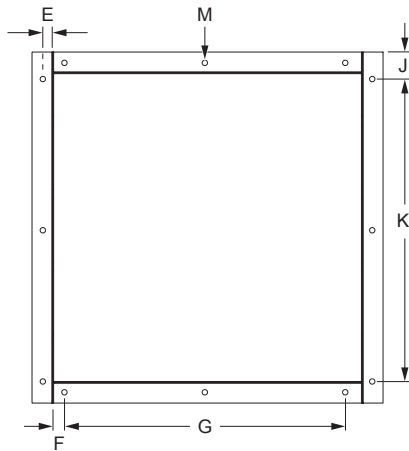

Dimension	Description
M _____ inches	Hole Diameter
E _____ inches	Centerline of Bolt Hole From Inside Edge of Frame
F _____ inches	First/Last Hole in Head/Sill
G ___ @ ___ inches	Number of Holes/Spacing in Head/Sill
J _____ inches	First/Last Hole in Jamb
K ___ @ ___ inches	Number of Holes/Spacing in Jamb

Airflow Performance Data

Pressure Loss vs. Velocity

Figure 5.5 — Plenum Mount

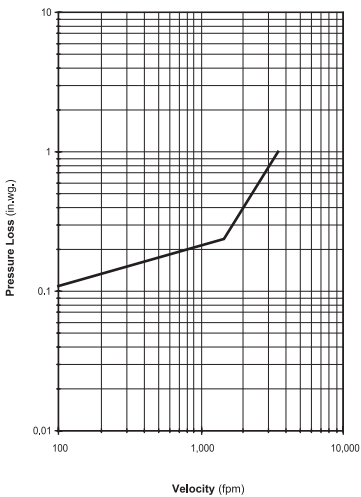

Pressure drop testing was performed in accordance with AMCA Standard 500-D using Figure 5.5 — Plenum Mount. All data has been corrected to represent air density of 0.075 lb/ft. Actual pressure drop in any ducted HVAC system is a combination of many elements. This information, along with analysis of other system influences, should be used to estimate actual pressure losses for a damper installed in a given HVAC system.



Plenum Mount

AMCA Figure 5.5 illustrates a plenum mounted damper. This configuration has the highest pressure drop because of extremely high entrance and exit losses due to the sudden changes of area in the system.

Pressure Limitations

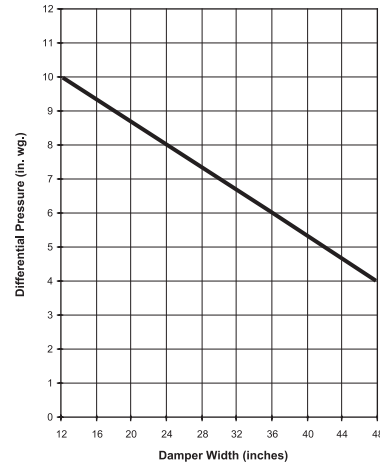

Velocity Limitations

