

Application

The EOJ-690 louver features operable J-blades that range from the closed position to fully open, and a drainable head to aid in protecting openings from water penetration. The EOJ-690 is ideally suited for use on warehouse, or distribution center type projects where maximum airflow is required.

Standard Construction

Material: Mill finish 6063-T5 extruded aluminum.

Frame: 6" deep × 0.081" thick (152 × 2) channel.

Blades: 90° × 0.081" (2) thick operable J-style.

Screen: 1/2" × 0.063" (12.7 × 1.6) expanded and flattened aluminum.

Mullion: Visible.

Minimum Size: 12" × 12" (305 × 305)

Maximum Size: Single section:
48" × 96" (1219 × 2436) with low leakage seals.
60" × 96" (1524 × 2436) without low leakage seals.
Multiple section: Unlimited

Options

- Factory finish:
 - High Performance Fluoropolymer
 - Baked Enamel/Polyester
 - Clear or Color Anodized, Class 1
 - Prime Coat
- Flange Frame:
 - 1 1/2" (38) flange
 - Custom-size flange
 - Stucco flange
 - Glazing frame
- Welded construction.
- Alternate bird or insect screens.
- Filter racks.
- Head and/or sill flashing.
- Sleeve (galvanized steel):
 - 20-GA 16-GA
- Installation hardware:
 - Clip angles Continuous angles
- Factory installed actuators:
 - Manual locking quadrant (supplied loose)
 - 24 VAC 120 VAC 230 VAC
 - Pneumatic Modulating

Ratings

Free Area: [48" × 48" (1219 × 1219) unit]: 10.96 ft² (3.34 m²)
68.5%

Performance @ Beginning Point of Water Penetration

Free Area Velocity: 748 fpm (3.80 m/s)
Air Volume Delivered: 8,325 cfm (3.93 m³/s)
Pressure Loss: 0.19 in.wg. (25 Pa)

Velocity @ 0.15 in.wg. Pressure Loss: 1,100 fpm (5.59 m/s)

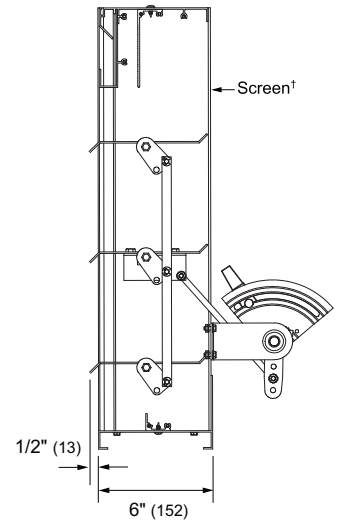
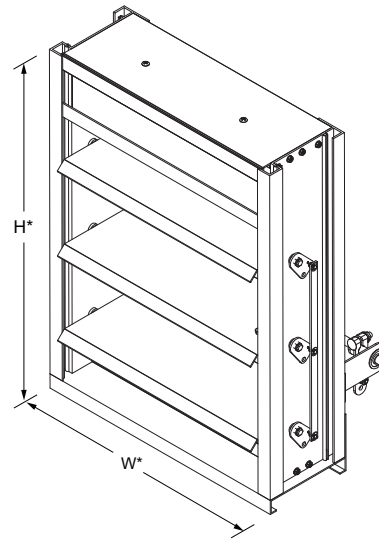

Model **EOJ-690**
(standard)

*Louver dimensions furnished approximately 1/2" (13) undersize.

Vertical Section

[†]Screen adds approximately 3/16" (5) to louver depth.

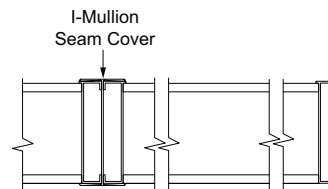

Vertical Mullion
(standard)

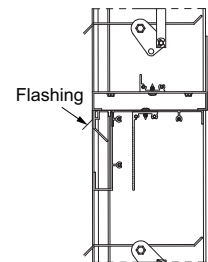

Horizontal Splice
(standard)

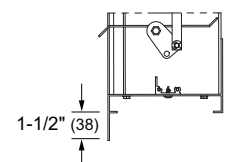

Flange Frame
(optional)

Free Area (ft²)

		Width (Inches)																		
		12	18	24	30	36	42	48	54	60	66	72	78	84	90	96	102	108	114	120
Height (Inches)	12	0.23	0.40	0.57	0.75	0.92	1.10	1.27	1.44	1.62	1.79	1.96	2.14	2.31	2.48	2.66	2.83	3.00	3.18	3.35
	18	0.52	0.92	1.32	1.72	2.12	2.52	2.92	3.32	3.72	4.11	4.51	4.91	5.31	5.71	6.11	6.51	6.91	7.31	7.70
	24	0.82	1.44	2.07	2.69	3.31	3.94	4.56	5.19	5.81	6.43	7.06	7.68	8.31	8.93	9.55	10.18	10.80	11.43	12.05
	30	1.11	1.96	2.81	3.66	4.51	5.36	6.21	7.06	7.91	8.76	9.61	10.46	11.31	12.16	13.01	13.86	14.70	15.55	16.40
	36	1.41	2.49	3.56	4.63	5.71	6.78	7.86	8.93	10.01	11.08	12.16	13.23	14.31	15.38	16.46	17.53	18.61	19.68	20.76
	42	1.71	3.01	4.31	5.61	6.91	8.21	9.51	10.81	12.11	13.41	14.71	16.01	17.31	18.61	19.91	21.21	22.51	23.81	25.11
	48	2.00	3.53	5.05	6.58	8.10	9.63	10.96	12.68	14.21	15.73	17.26	18.78	20.31	21.84	23.36	24.89	26.41	27.94	29.46
	54	2.30	4.05	5.80	7.55	9.30	11.05	12.80	14.56	16.31	18.06	19.81	21.56	23.31	25.06	26.81	28.56	30.31	32.07	33.82
	60	2.59	4.57	6.55	8.52	10.50	12.48	14.45	16.43	18.41	20.38	22.36	24.33	26.31	28.29	30.26	32.24	34.22	36.19	38.17
	66	2.89	5.09	7.29	9.50	11.70	13.90	16.10	18.30	20.50	22.71	24.91	27.11	29.31	31.51	33.72	35.92	38.12	40.32	42.52
	72	3.19	5.61	8.04	10.47	12.89	15.32	17.75	20.18	22.60	25.03	27.46	29.89	32.31	34.74	37.17	39.59	42.02	44.45	46.88
	78	3.48	6.13	8.79	11.44	14.09	16.74	19.40	22.05	24.70	27.36	30.01	32.66	35.31	37.97	40.62	43.27	45.92	48.58	51.23
	84	3.78	6.66	9.53	12.41	15.29	18.17	21.05	23.92	26.80	29.68	32.56	35.44	38.31	41.19	44.07	46.95	49.83	52.71	55.58
	90	4.07	7.18	10.28	13.38	16.49	19.59	22.69	25.80	28.90	32.00	35.11	38.21	41.32	44.42	47.52	50.63	53.73	56.83	59.94
	96	4.37	7.70	11.03	14.36	17.68	21.01	24.34	27.67	31.00	34.33	37.66	40.99	44.32	47.65	50.97	54.30	57.63	60.96	64.29
	102	4.66	8.22	11.77	15.33	18.88	22.44	25.99	29.55	33.10	36.65	40.21	43.76	47.32	50.87	54.43	57.98	61.53	65.09	68.64
108	4.96	8.74	12.52	16.30	20.08	23.86	27.64	31.42	35.20	38.98	42.76	46.54	50.32	54.10	57.88	61.66	65.44	69.22	73.00	
114	5.26	9.26	13.27	17.27	21.28	25.28	29.29	33.29	37.30	41.30	45.31	49.31	53.32	57.32	61.33	65.33	69.34	73.34	77.35	
120	5.55	9.78	14.01	18.24	22.47	26.71	30.94	35.17	39.40	43.63	47.86	52.09	56.32	60.55	64.78	69.01	73.24	77.47	81.70	

Water Penetration

Beginning Point of Water Penetration = Above 1250 fpm

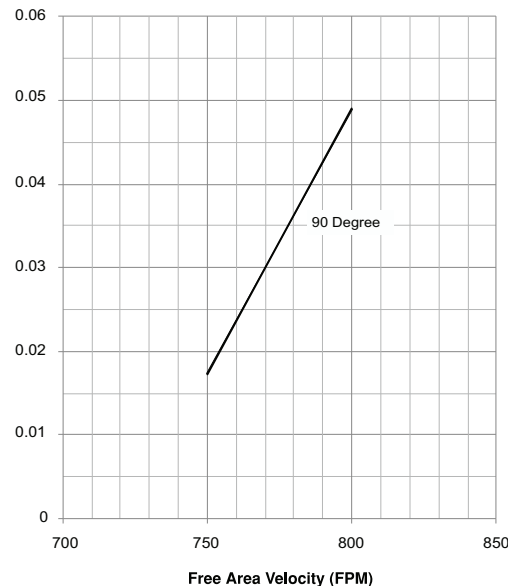
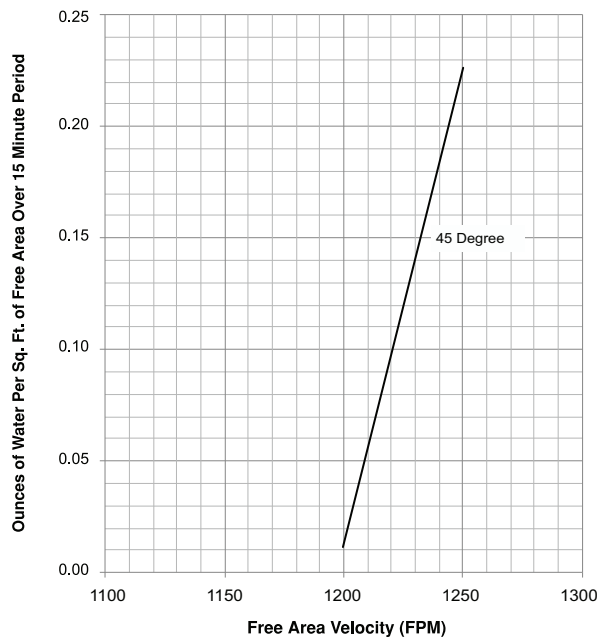

Water Penetration

AMCA defines the beginning point of water penetration as the free area velocity at the intersection of a simple linear regression of test data and the line of 0.01 ounces of water per square foot of free area and is measured through a 48" x 48" louver during a 15 minute period. The AMCA water penetration test provides a method for comparing louver models and designs as to their efficiency in resisting the penetration of rainfall under specific lab conditions. C&S recommends that intake louvers are selected with a reasonable margin of safety below the beginning point of water penetration in order to avoid unwanted penetration during severe storm conditions.

Pressure Loss (Standard Air Density @ 0.075 lbs./ft.)

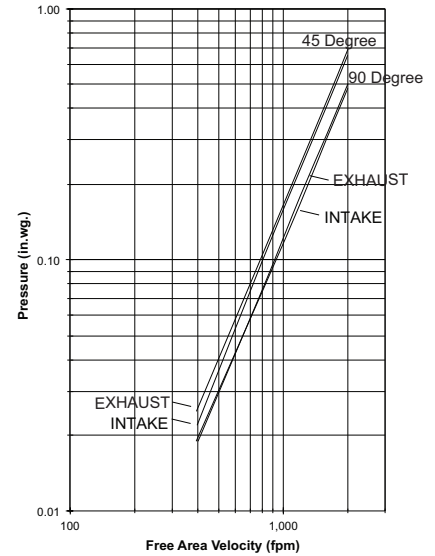
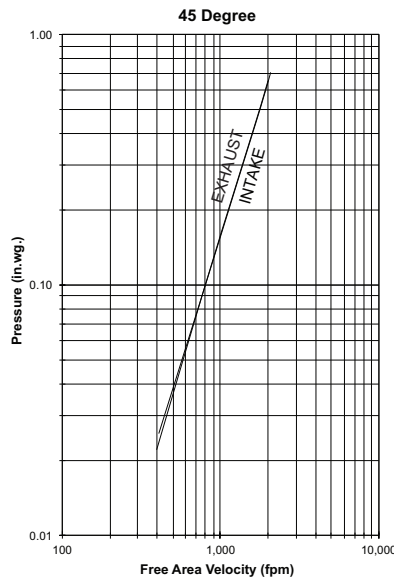
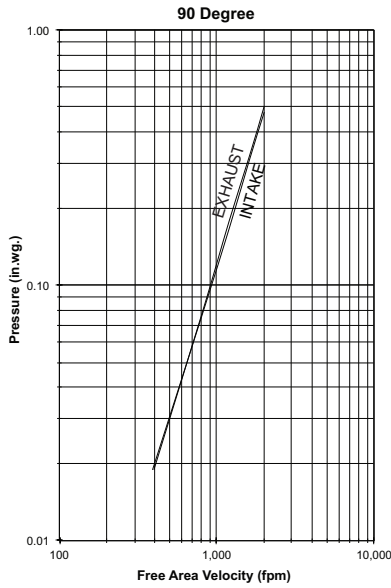

Louver Test Size = 48" x 48" (1219 x 1219)
 Pressure loss tested in accordance with Figure 5.5 of AMCA Standard 500-L.

Selection Criteria

Follow the steps listed below to calculate the louver size needed to satisfy the required air volume while minimizing the adverse effects of water penetration and pressure loss.

1. Determine the Free Area Velocity (FAV) at the maximum allowable pressure loss using the *Pressure Loss* chart to the left. While job conditions vary, typically, the maximum allowable pressure loss should not exceed 0.15 in.wg., and the FAV for 0.15 in.wg. pressure loss is listed on the front page of this sheet.
2. **Intake Applications** If the FAV at the Beginning Point of Water Penetration (shown below) is less than the FAV from step 1, then use the FAV at the Beginning Point of Water Penetration in step 3, otherwise use the FAV from step 1.
- Exhaust Applications** Use the FAV from step 1 in step 3.
3. Calculate the total louver square footage required using the following equation.

$$\frac{\text{Required Air Volume}}{\text{cfm}} \div \frac{\text{FAV}}{\text{fpm}} = \frac{\text{Required Louver (Free-Area) Size in ft}^2}{\text{ft}^2}$$

4. Using the *Free Area* chart above, select a louver width and height that yields a free area ft² greater than or equal to the required louver size calculated in step 3.

Extruded Aluminum Louvers **EO-J690** (3/3) January 2018