

The following installation details apply to model **FD35R**

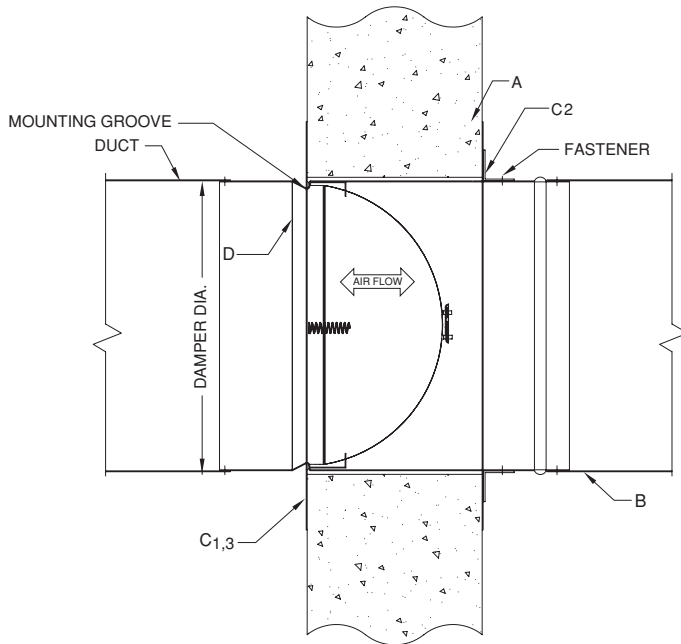

Figure 1

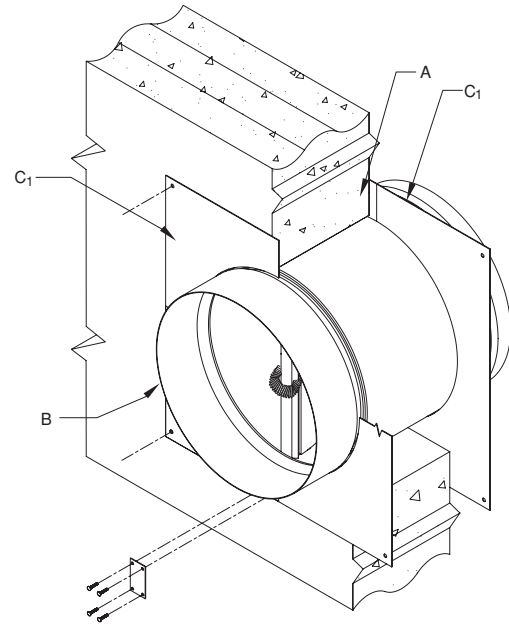

Figure 2

- A.** Concrete or masonry fire partition is shown in figure 1 and 2. The square or round opening shall be a minimum of 1/4" (6) with a maximum of 3/4" (19) larger, but less than 6" (152) the mounting angles must be a minimum of 16 gauge (1.5) and must be tall enough to overlap the opening by a minimum of 1" (25). Damper must be installed with leading edge of closed blade within the partition.
- B.** The connecting duct shall not be continuous, and shall terminate at the sleeve/frame using one or more of commonly used break away style connections. Refer to Sleeve Termination Supplemental Installation Instructions for further details. Damper sleeve shall not extend more than 6" (152) beyond the rated partition unless an access door is installed in the sleeve which then permits the extension to be a maximum of 16" (406).
- C1.** The holding plate mounting groove of damper sleeve must be flush with wall. Seat the holding plate (see figures 3 & 4) into the mounting groove. Then place guide plate (see figures 3 & 4) around the opposite side of damper sleeve and slide forward until it touches partition. Secure both plates with joiner clips (see figure 5) using four 1/8" (3) minimum rivets, #10 (M5) sheet metal screws, bolts or welds per joiner clip. A minimum of 3 clip angles (see figure 7) shall be arranged symmetrically around the damper and fastened to the damper sleeve on the guide plate side of the partition and in contact with the guide plate. Fasteners shall be #10 (M5) screws, bolts, 1/8" (5) rivets or welds.
- C2.** As a further option for round openings either or both plates may be replaced by 1-1/2" x 1-1/2" x 20 gauge (38 x 38 x 1) minimum angle rings. Each ring shall be fastened to the damper sleeve, not the partition, at 8" (3) on center maximum with a minimum of 3 fasteners using #10 (M5) sheet metal screws, bolts, 1/8" (3) diameter rivets or welds.
- D.** On non-integral sleeve units, when fastening the damper to the sleeve, the damper shall be fastened with 3/16" (4.8) diameter steel rivets, Quick-Lock joints, welds or No. 10 (M5) bolts or sheet metal screws at 8" (203) o.c. maximum. A minimum of two connections per assembly.

Note:

Annular space between damper sleeve and wall opening shall not be filled with firestop materials such as fill, void or cavity materials.

Fire Dampers IIFD35R (1/2), June 2006

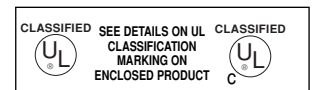

Underwriter's Laboratories file #R14981.
The product is also listed by CSFM File # 3225-1404:110

Information is subject to change without notice or obligation.

NOTE: Dimensions in parentheses () are millimeters.

The following installation details apply to model **FD35R**

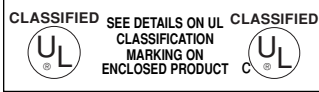

DESCRIPTION

- A - VFD-35R Fire Damper.
- B - Holding Plate, 20 ga.(1) steel.
- C - Guide Plate, 20 ga. (1) steel.
- D - Joiner Clip, 20 ga. (1) steel, typical both plates.
- E - 1/8" (3) Dia. Steel Pop Rivet, or #10 (M5) x 1/2" (13) Sheet Metal Screw.

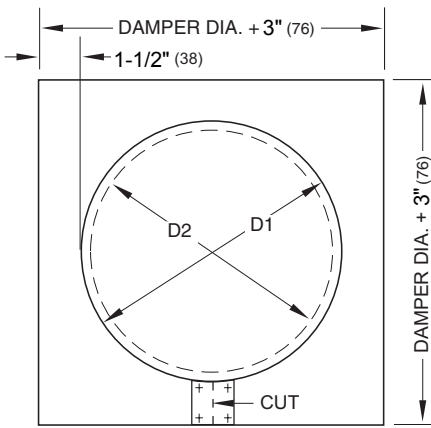
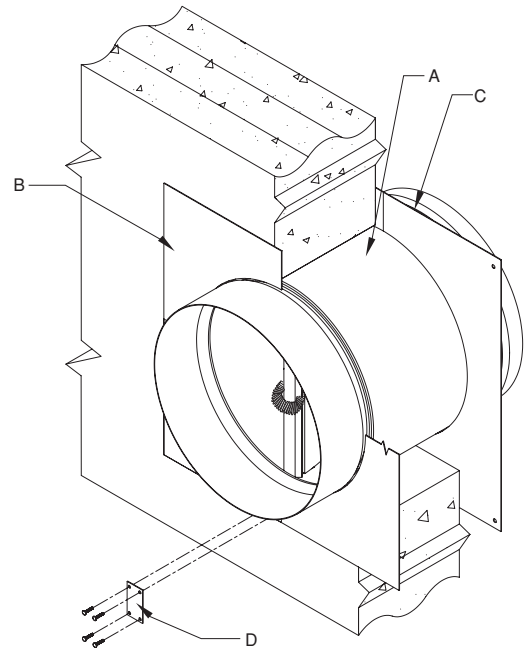

D1 = DAMPER DIA. FOR GUIDE PLATE
 D2 = DAMPER DIA. - 3/8" (10) FOR HOLDING PLATE

Figure 3
 Guide Plate & Holding Plate Detail

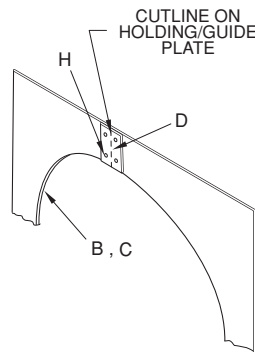

Figure 4
 Joiner Clip Assembly

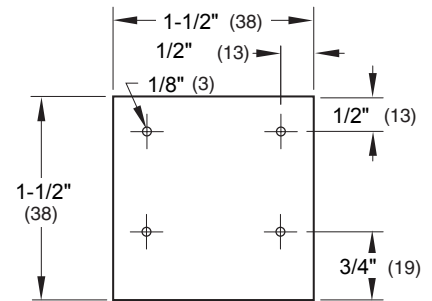

Figure 5
 Joiner Clip
 - 20 GA. (1) Galv. Steel -

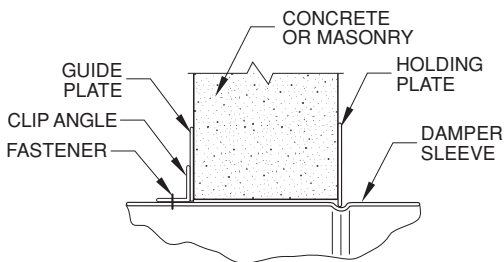

Figure 6
 Concrete Partition Detail

Underwriter's Laboratories file #R14981.
 The product is also listed by CSFM File # 3225-1404:110

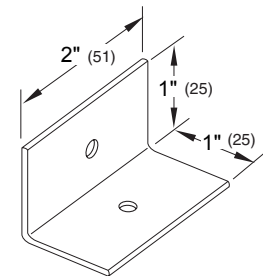

Figure 7
 Clip Angle
 - 20 GA. (1) Galv. Steel -