

The following installation details apply to models **FSD-131-OP** and **FSD-132-OP**

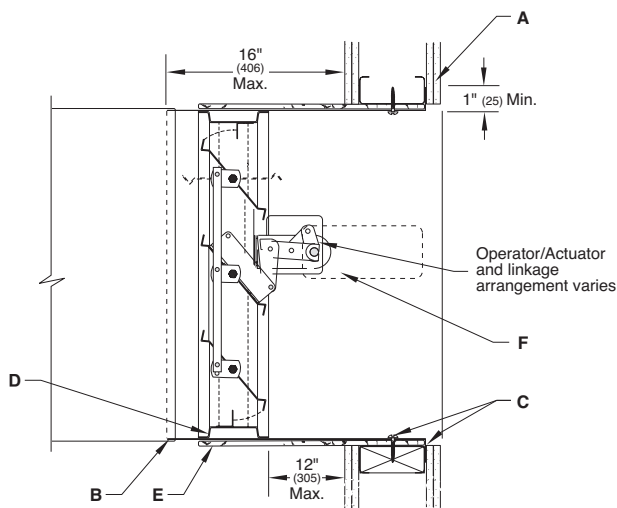

### Vertical Mount

- Notes:**
- All dimensions shown in ( ) are in millimeters.
  - Illustration depicts damper installed vertical right side up. Damper may also be installed up side down.

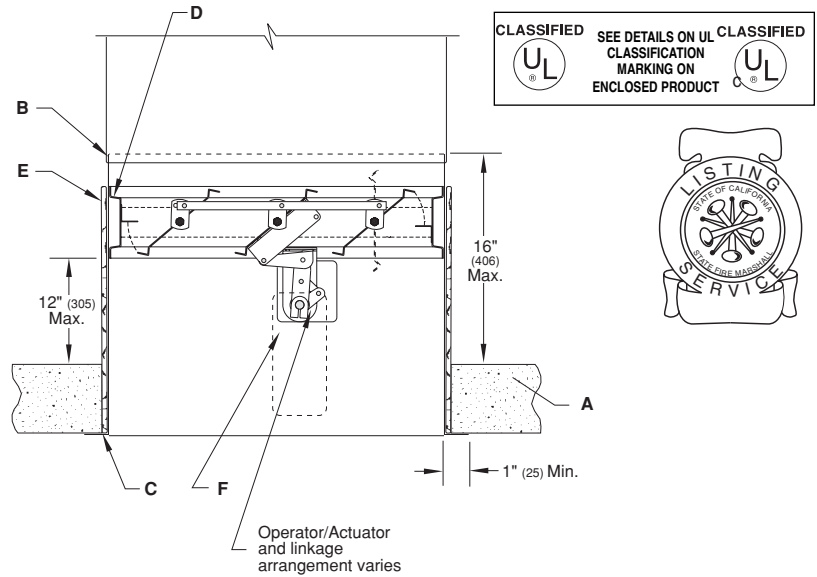

### Horizontal Mount

- Not applicable to wood stud construction
- Illustration depicts damper installed from the top down with the actuator above the ceiling line. Damper may also be installed from the bottom up with the actuator below the ceiling line.

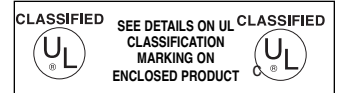

- A. Typical 2 hour steel/wood stud vertical and concrete horizontal fire partition shown. See Steel Stud Framing for Fire Dampers in Dry Wall and/or Cavity Shaft Wall Partitions Supplemental Installation Instructions for further vertical mount installation details. The opening shall be a minimum of 1/4" (6) with a maximum of 3/4" (19) larger than the overall damper and sleeve assembly size. When openings are larger than 3/4" (19), but less than or equal to 6" (152) the mounting angles must be a minimum of 16 gauge (1.5) and must be tall enough to overlap the opening by a minimum of 1" (25). Damper must be installed with leading edge of the damper frame no more than 12" (305) outside the partition.
- B. For rigid type duct connections, the sleeve shall be a minimum of 16 gauge (1.5). When lighter gauge sleeves are used, one or more of commonly used break away style connections are required. Refer to Sleeve Termination Supplemental Installation Instructions for further details. In no case will the sleeve gauge be less than the duct gauge to which it is connected. Damper sleeve shall not extend more than 16" (406) beyond the rated partition.
- C. Mounting flange shall be a minimum of 1" x 20 gauge (25 x 1). The flange shall be attached to the sleeve with a minimum of 3/16" (4.8) diameter steel rivets. Quick Lock joint, welds, or No.10 (M5) bolts or sheet metal screws at 8" (203) o.c. maximum. The damper sleeve shall be fastened directly to the partition with a minimum of 3/16" (4.8) diameter steel rivets, or No.10 (M5) sheet metal screws at 8" (203) o.c. maximum. A minimum of two connections per side, top, bottom. A minimum 1-1/2" x 3/4" x 20 gauge (38 x 19 x 1) mounting angle may be used on the opposite side of the partition from the mounting flange in lieu of fastening the sleeve directly to the partition. When using mounting angles they shall be attached to the sleeve under the same guideline as the mounting flange.

**Notes:**

1. The annular space between damper sleeve and wall opening must not be filled with firestop materials such as fill, void, or cavity materials. However, if optional sealing between the retaining angle (or flange) leg and the surface of the partition, wall, or floor and/or between the retaining angle leg and the surface of the damper sleeve is required, any of the following sealants may be used:

Dow-Corning 700 or 732 GE RTV 108 or SCS 1201 RTV

These sealants must be applied such that they do not intrude into the annular space between the outside surface of the damper sleeve and the opening of the partition, wall or floor into which the damper/sleeve is being installed.

2. In order to run the necessary electrical wiring or pneumatic piping/tubing to facilitate supplying power to the actuator it will be necessary to cut a hole in the damper sleeve. Care should be taken such that the hole is as small as possible but will still permit the necessary electrical wiring or pneumatic piping/tubing to connect through and/or attach to the sleeve. As is always the case, all electrical and pneumatic connections should be done in accordance with the local code requirements.

- D. When fastening the damper to the sleeve, the damper shall be fastened with a minimum of 3/16" (4.8) diameter steel rivets, Quick-Lock Joints, welds, or No. 10 (M5) bolts or sheet metal screws at 8" (203) o.c. maximum. A minimum of two connections per side, top, bottom.
- E. A factory installed minimum of one layer of thermal blanket wrap shall encase the exterior of the damper sleeve and shall span the entire length of the sleeve from the outer most edge of the damper frame to the mounting flange. Care should be taken during handling & installation to prevent tearing or bending of the material. To aid in this the thermal blanket may be fastened to the sleeve with adhesive.
- F. Fire/Leakage rated dampers and qualified operators are tested together by Underwriters Laboratories and are factory installed to qualify for standard damper/operator warranties. Damper operator/actuator must be tested prior to system start-up to ensure proper operation. Before applying power to the operator/actuator, the power must be verified.

The product is also listed by CSFM file # 3225-1404:110 and 3230-1404:111 and conforms to NFPA 90-A and NFPA 92-A.  
Underwriter's Laboratories file #R14981

Information is subject to change without notice or obligation.

**NOTE:** Dimensions in parentheses ( ) are millimeters.

The following installation details apply to models **FSD-131-OP** and **FSD-132-OP**

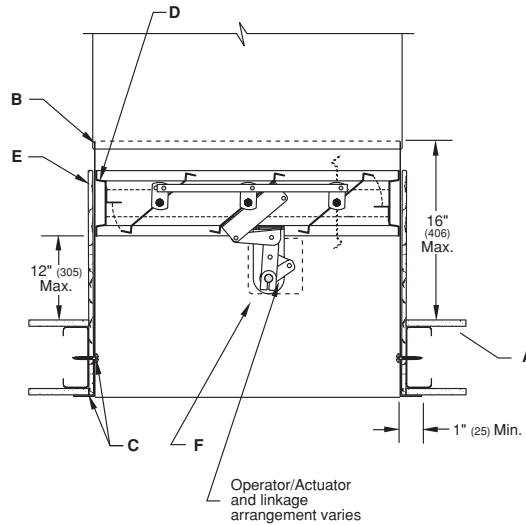
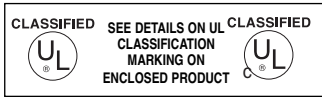

**Horizontal Mount**

**Notes:**

- All dimensions shown in ( ) are in millimeters.
- Not applicable to wood stud construction.
- Illustration depicts damper installed from the top down with the actuator above the ceiling line.  
Damper may also be installed from the bottom up with the actuator below the ceiling line.

- A. Typical 1 hour steel stud framed tunnel type ceiling shown. See Steel Stud Framing for Fire Dampers In Tunnel Corridor Drywall and/or Cavity Shaftwall Ceilings Supplemental Installation Instructions for further details. The opening shall be a minimum of 1/4" (6) larger than the overall damper and sleeve assembly size. Damper must be installed with leading edge of the damper frame no more than 12" (305) outside the partition.
- B. For rigid type duct connections, the sleeve shall be a minimum of 16 gauge (1.5). When lighter gauge sleeves are used, one or more of commonly used breakaway style connections are required. Refer to Sleeve Termination Supplemental Installation Instructions for further details. In no case will the sleeve gauge be less than the duct gauge to which it is connected. Damper sleeve shall not extend more than 16" (406) beyond the rated partition.
- C. Mounting flange shall be a minimum of 1" x 20 gauge (25 x 1). The flange shall be attached to the sleeve with a minimum of 3/16" (4.8) diameter steel rivets, Quick-Lock joint, welds, No.10 (M5) bolts or sheet metal screws at 8" (203) o.c. maximum. The damper sleeve shall be fastened directly to the partition with a minimum of 3/16" (4.8) diameter steel rivets, or No.10 (M5) sheet metal screws at 8" (203) o.c. maximum. A minimum of two connections per side, top and bottom. A minimum 1-1/2" x 3/4" x 20 gauge (38 x 19 x 1) mounting angle may be used on the opposite side of the partition from the mounting flange in lieu of fastening the sleeve directly to the partition. When using mounting angles they shall be attached to the sleeve under the same guideline as the mounting flange.

**Notes:**

1. The annular space between damper sleeve and wall opening must not be filled with firestop materials such as fill, void, or cavity materials. However, if optional sealing between the retaining angle (or flange) leg and the surface of the partition, wall, or floor and/or between the retaining angle leg and the surface of the damper sleeve is required, any of the following sealants may be used:

Dow-Corning 700 or 732

GE RTV 108 or SCS 1201 RTV

These sealants must be applied such that they do not intrude into the annular space between the outside surface of the damper sleeve and the opening of the partition, wall or floor into which the damper/sleeve is being installed.

2. In order to run the necessary electrical wiring or pneumatic piping/tubing to facilitate supplying power to the actuator it will be necessary to cut a hole in the damper sleeve. Care should be taken such that the hole is as small as possible but will still permit the necessary electrical wiring or pneumatic piping/tubing to connect through and/or attach to the sleeve. As is always the case, all electrical and pneumatic connections should be done in accordance with the local code requirements.

- D. When fastening the damper to the sleeve, the damper shall be fastened with a minimum of 3/16" (4.8) diameter steel rivets, Quick-Lock Joints, welds, No. 10 (M5) bolts or sheet metal screws at 8" (203) o.c. maximum. A minimum of two connections per side, top and bottom.
- E. A factory installed minimum of one layer of thermal blanket wrap shall encase the exterior of the damper sleeve and shall span the entire length of the sleeve from the outer most edge of the damper frame to the mounting flange. Care should be taken during handling & installation to prevent tearing or bending of the material. To aide in this the thermal blanket may be fastened to the sleeve with adhesive.
- F. Fire/Leakage rated dampers and qualified operators are tested together by Underwriters Laboratories and are factory installed to qualify for standard damper/operator warranties. Damper operator/actuator must be tested prior to system start-up to ensure proper operation. Before applying power to the operator/actuator, the power must be verified.

**Special Notes for Dampers Installed in Wood Stud Construction:**

1. The opening must be made larger to permit the attachment of gypsum wallboard to all four sides of the outside of the damper sleeve. The wallboard must be a minimum of 1/2" thick and must be UL rated for use in fire protective construction. Therefore, if 1/2" thick wallboard is used, the opening will have to be 1" wider and 1" higher than normal.
2. The wallboard must be attached to outside of the damper sleeve with a minimum of 2 drywall screws on each of the sides. The screws should be located approx. 1-1/2" from the back edge of the sleeve and approx. 1-1/2" away from the perpendicular side to which it is being attached. The screws should be a #6 or larger and must be 3/8" longer than the thickness of the drywall attached to the sleeve.
3. In lieu of the sleeve to partition attachment details above, the damper/sleeve must be attached to the opening with min. #10 screws (drywall, wood or equivalent), 3" long. The screws must be at a max. of 8" o.c. and must be located such that they penetrate the wood framing members around the opening.
4. A steel grille must be installed on the flange of the damper sleeve. The grille must be a min. of 24 ga. thick and have a flange that overlaps the damper flange a min. of 1".