

## Application

MD-41 and MD-42 balancing dampers employ triple-V blades and a rugged hat channel frame for manual air control and balancing in medium pressure and velocity applications.

## Standard Construction

**Frame:** 5" x 1" (127 x 25) galvanized steel hat channel with interlocking corner gusset. Equivalent to 13 gauge (2.4) channel frame. Low profile head and sill are used on sizes less than 13" (330) high.

**Blades:** 6" x 16 gauge (152 x 1.5) galvanized steel — triple-V. Parallel (model MD-41) or opposed (model MD-42) action.

**Axles:** 1/2" (13) diameter plated steel hex.

**Linkage:** Concealed in frame.

**Bearings:** Synthetic

**Control Shaft:** 1/2" x 6" (13 x 152) round drive axle with outboard shaft support bracket and bearing supplied on all single section dampers for field installation. Factory installed jackshaft supplied with all multiple section dampers.

**Minimum Size:** Model MD-41 (one blade): 6" x 5" (152 x 127)  
Model MD-41 and MD-42 (two blades):  
6" x 10" (152 x 254)

**Maximum Size:** Single section: 48" x 48" (1219 x 1219)  
Multiple sections: 96" x 96" (2438 x 2438)

## Options

- Manual locking quadrant (supplied loose)
- Flanged frame:  One side  Both sides
- Actuator/Quadrant standoff bracket — accommodates up to 3" (76) thick insulated duct.
- Stainless steel oilite sleeve-type bearings.
- No Top or Bottom Stops

## Ratings

Damper Width	Maximum System Pressure	Maximum System Velocity
12" (305)	5.0 in. wg (1.2 kPa)	2000 fpm (10.2 m/s)
24" (610)	4.0 in. wg (1.0 kPa)	2000 fpm (10.2 m/s)
36" (914)	3.0 in. wg (0.8 kPa)	2000 fpm (10.7 m/s)
48" (1219)	2.5 in. wg (0.6 kPa)	1500 fpm (7.6 m/s)

**Temperature:** -40°F to 180°F (-40°C to +83°C)

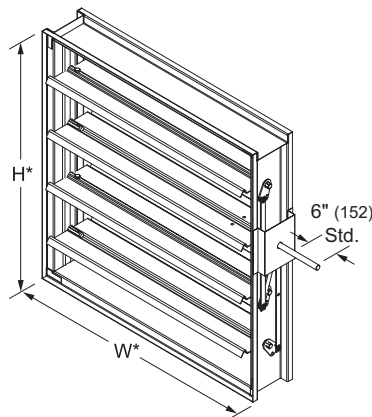

**Model MD-42 (standard)**  
\*Damper dimensions furnished approximately 1/4" (6) undersize. (Drive axle supplied loose for field installation)

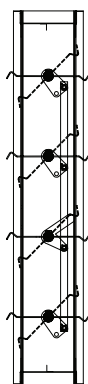

**MD-41**



**MD-42**

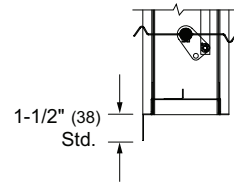

**Flanged Frame**

# Typical Damper Dimensional Details

Dampers are designed to be self-supporting in the maximum single section size. When dampers are installed in multiple section assemblies, bracing may be required to support the weight of the dampers and to ensure structural integrity against system pressures. It is recommended that multiple sections be appropriately braced. In horizontal installations, it is recommended that suitable supports be installed every 8 feet of damper width. Dampers installed in vertical multiple assemblies and/or higher system pressures, may require additional bracing.

Damper dimensions furnished approximately 1/4" (6) undersize.

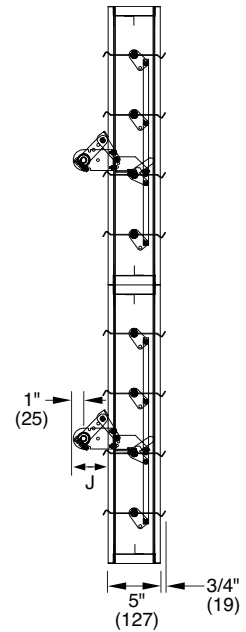
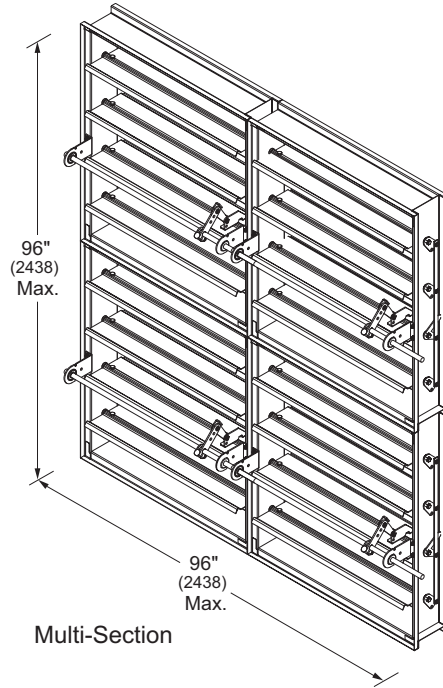

**Note:** J = 2" (51) for H < 8" (203)  
J = 3 3/8" (86) for H ≥ 8" (203)

## Airflow Performance Data

### Pressure Loss vs. Velocity

Figure 5.3 — Ducted Inlet and Outlet

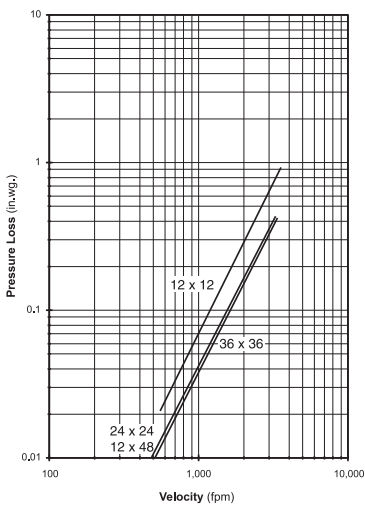

Figure 5.2 — Ducted Inlet

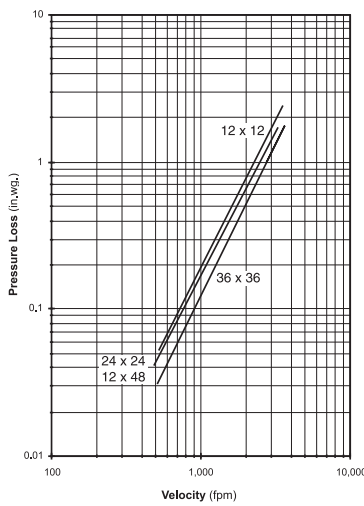
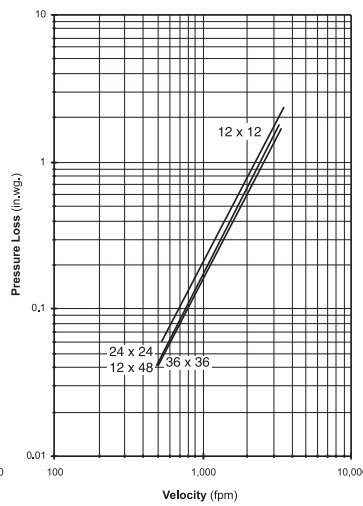

Figure 5.5 Plenum Mount



Pressure drop testing was performed in accordance with AMCA Standard 500-D using the three configurations shown. All data has been corrected to represent air density of 0.075 lb/ft. Actual pressure drop in any ducted HVAC system is a combination of many elements. This information, along with analysis of other system influences, should be used to estimate actual pressure losses for a damper installed in a given HVAC system.



#### Ducted Inlet and Outlet

AMCA Figure 5.3 illustrates a fully ducted damper. This configuration represents the lowest pressure drop of the three test configurations because entrance and exit losses are minimized by straight duct runs upstream and downstream of the damper.

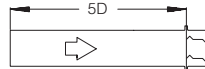

#### Ducted Inlet

AMCA Figure 5.2 illustrates a ducted damper exhausting air into an open area. This configuration has a lower pressure drop than Figure 5.5 because entrance losses are minimized by a straight duct run upstream of the damper.



#### Plenum Mount

AMCA Figure 5.5 illustrates a plenum mounted damper. This configuration has the highest pressure drop because of extremely high entrance and exit losses due to the sudden changes of area in the system.