

Application

The SE-445 combination louver features stationary louver blades and an integral gravity operated backdraft damper to protect exhaust air openings in exterior walls. The SE-445 is available in a wide array of painted finishes including custom color matching.

Standard Construction

Material: Galvanized steel.

Frame: 4" deep × 20 ga. thick (102 × 1) channel.

Blades: 45° × 20 ga. (1) thick J-style BD-exhaust.

Screen: 1/2" × 0.063" (12.7 × 1.6) expanded and flattened aluminum.

Mullion: Visible.

Minimum Size: 12" × 12" (305 × 305)

Maximum Size: Single section: 36" × 96" (914 × 2438)
Multiple section: Unlimited

Options

- Factory finish:
 - Polyester Powder
 - Baked Enamel
 - Prime Coat
- 1 1/2" (38) flange frame.
- Welded construction.
- Alternate bird or insect screens.
- Insulated or non-insulated blank-off panels.
- Filter racks.
- Hinged frame.
- Heavy duty 16 ga. (1.6) construction.
- 304 stainless steel construction.

Ratings

Free Area: [48" × 48" (1219 × 1219) unit]: 7.5 ft² (0.70 m²)
46.9%

Performance @ Beginning Point of Water Penetration

Free Area Velocity: 775 fpm (3.94 m/s)

Air Volume Delivered: 5,813 cfm (2.75 m³/s)

Pressure Loss: 0.13 in.wg. (32 Pa)

Velocity @ 0.15 in.wg. Pressure Loss: 840 fpm (4.26 m/s)

Design Load: 30 psf

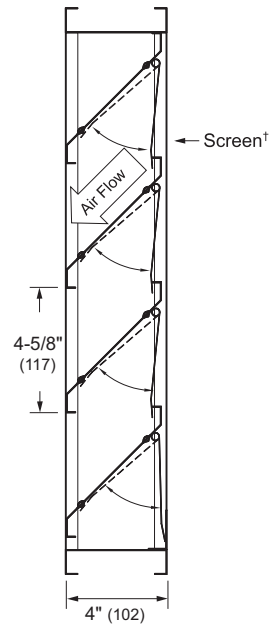
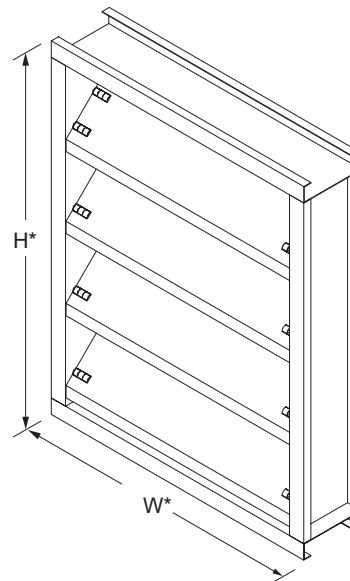

Model **SE-445**
(standard)

*Louvers dimensions furnished approximately 1/2" (13) undersize.

Vertical Section

†Screen adds approximately 3/16" (5) to louver depth.

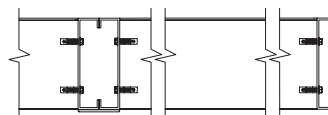

Vertical Mullion
(standard)

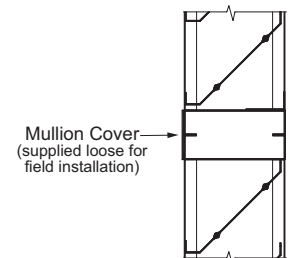

Horizontal Mullion
(standard)

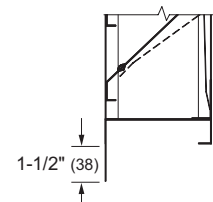

Flange Frame
(optional)

Performance Data

Free Area (ft²)

		Width (Inches)														
		12	18	24	30	36	42	48	54	60	66	72	78	84	90	96
Height (Inches)	12	0.2	0.3	0.5	0.6	0.7	0.8	1.0	1.1	1.2	1.3	1.4	1.5	1.7	1.8	1.9
	18	0.5	0.8	1.0	1.3	1.6	1.9	2.1	2.4	2.7	3.0	3.3	3.5	3.8	4.8	4.4
	24	0.8	1.2	1.6	2.1	2.5	2.9	3.4	3.8	4.2	4.7	5.1	5.5	6.0	6.4	6.8
	30	0.9	1.4	1.9	2.4	2.9	3.4	3.9	4.4	4.9	5.4	5.9	6.4	6.9	7.4	7.9
	36	1.2	1.8	2.5	3.1	3.8	4.5	5.1	5.8	6.4	7.1	7.8	8.4	9.1	9.7	10.4
	42	1.4	2.2	3.1	3.9	4.7	5.5	6.3	7.2	8.0	8.8	9.6	10.4	11.2	12.1	12.9
	48	1.7	2.7	3.7	4.6	5.6	6.6	7.5	8.5	9.5	10.5	11.4	12.4	13.4	14.4	15.3
	54	1.8	2.9	3.9	5.0	6.0	7.0	8.1	9.1	10.2	11.2	12.3	13.3	14.3	15.4	16.4
	60	2.1	3.3	4.5	5.7	6.9	8.1	9.3	10.5	11.7	12.9	14.1	15.3	16.5	17.7	18.9
	66	2.4	3.7	5.1	6.4	7.8	9.2	10.5	11.9	13.2	14.6	15.9	17.3	18.7	20.0	21.4
	72	2.5	3.9	5.3	6.8	8.2	9.6	11.1	12.5	13.9	15.3	16.8	18.2	19.6	21.0	22.5
	78	2.8	4.3	5.9	7.5	9.1	10.7	12.3	13.8	15.4	17.0	18.6	20.2	21.8	23.3	24.9
	84	3.0	4.8	6.5	8.3	10.0	11.7	13.5	15.2	17.0	18.7	20.4	22.2	23.9	25.7	27.4
	90	3.3	5.2	7.1	9.0	10.9	12.8	14.7	16.6	18.5	20.4	22.3	24.2	26.1	28.0	29.9
	96	3.4	5.4	7.4	9.3	11.3	13.3	15.2	17.2	19.2	21.1	23.1	25.1	27.0	29.0	31.0

Pressure Loss

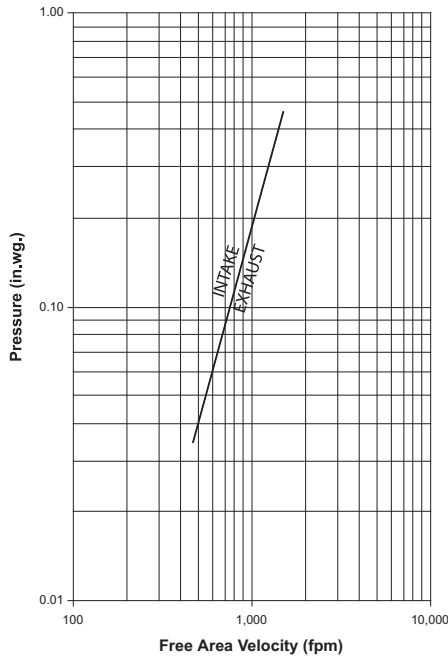

Louver Test Size = 48" x 48" (1219 x 1219)

Note: Operable blades begin to open at 0.01" w.g. (2.5 Pa).
 Operable blades are fully open at 0.25" w.g. (62.1 Pa).
 Louver Test Size = 24" x 24" (610 x 610).
 Louver tested with ducted inlet and outlet.

Selection Criteria

Follow the steps listed below to calculate the louver size needed to satisfy the required air volume while minimizing the adverse effects of water penetration and pressure loss.

1. Determine the Free Area Velocity (FAV) at the maximum allowable pressure loss using the *Pressure Loss* chart to the left. While job conditions vary, typically, the maximum allowable pressure loss should not exceed 0.15 in.wg., and the FAV for 0.15 in.wg. pressure loss is listed on the front page of this sheet.
2. **Intake Applications** If the FAV at the Beginning Point of Water Penetration (shown below) is less than the FAV from step 1, then use the FAV at the Beginning Point of Water Penetration in step 3, otherwise use the FAV from step 1.
- Exhaust Applications** Use the FAV from step 1 in step 3.
3. Calculate the total louver square footage required using the following equation.

$$\frac{\text{Required Air Volume (cfm)}}{\text{FAV (fpm)}} = \text{Required Louver (Free-Area) Size (ft}^2\text{)}$$

4. Using the *Free Area* chart above, select a louver width and height that yields a free area ft² greater than or equal to the required louver size calculated in step 3.